

Material handling equipment

9010 - Horizontal clamp

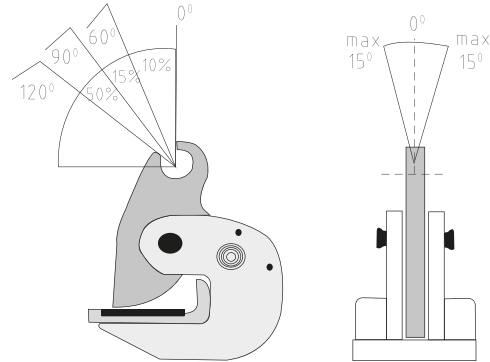

Description:

- Designed for transferring, tilting and stacking steel plates in the horizontal plain
- These clamps must always be used in pairs
- CE, Traceability code, WLL, Jaw opening & GRIPTON mentioned in label
- CE, Traceability code, WLL & GRIPTON mentioned on label

Standard:	EN 12195
Material:	Jaw: Alloy steel, Body: Carbon steel
Factor of safety:	4 to 1
Construction:	Quenched & tempered Jaw
Proof load:	Individually proof tested to 2 times of working load limit
Finish:	Powder coated

Horizontal plate lifting clamp

Part No.	WLL (T) per pair	Jaw opening (mm)	Net weight (Kg)
9010.0010	1	0 - 30	3.5
9010.0015	1.5	0 - 30	4
9010.0020	2	0 - 40	5
9010.0030	3	0 - 45	6
9010.0040	4	0 - 50	6.5
9010.0050	5	0 - 55	7.5
9010.0060	6	0 - 65	10.5
9010.006L	6	0 - 130	22
9010.0080	8	0 - 100	22
9010.0100	10	0 - 125	33