

## Material handling equipment

### 6150 - Lever block

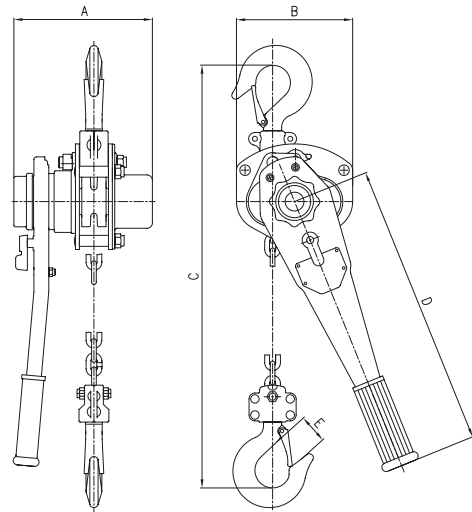

#### Description:

- Compact design & light weight for ease of use
- Heat treated body, shafts & gears for enhanced strength
- Forged lifting and suspension hooks, with safety latches
- Free-wheeling mechanism for quick chain adjustment
- CE, Serial number, SWL & H.O.L shown on label and carton.

Standard:	EN 13157
Material:	Forged alloy steel
Factor of safety:	4 to 1
Construction:	Quenched & tempered
Proof load:	Individually proof tested to 1.5 time of working load limit
Finish:	Powder coated

#### Lever block

Part No.	Rated load (T)	Standard lift (M)	Test load (T)	Effort required at capacity (N)	Load chain diameter (mm)	No. of load chains	A (mm)	B (mm)	C (mm)	D (mm)	E (mm)	Min. distance between two hooks	Net weight (Kg)
6150.0075	0.75	1.5	1.125	140	6.00	1	152	128	295	256	26	295	7.7
6150.0150	1.5	1.5	2.25	234	7.10	1	175	148	335	368	30	335	10.6
6150.0300	3	1.5	4.5	363	10	1	195	181	450	368	34	450	20
6150.0600	6	1.5	9	370	10	2	195	232	615	368	47	615	28
6150.0900	9	1.5	13.5	375	10	3	195	366	720	368	64	720	46